

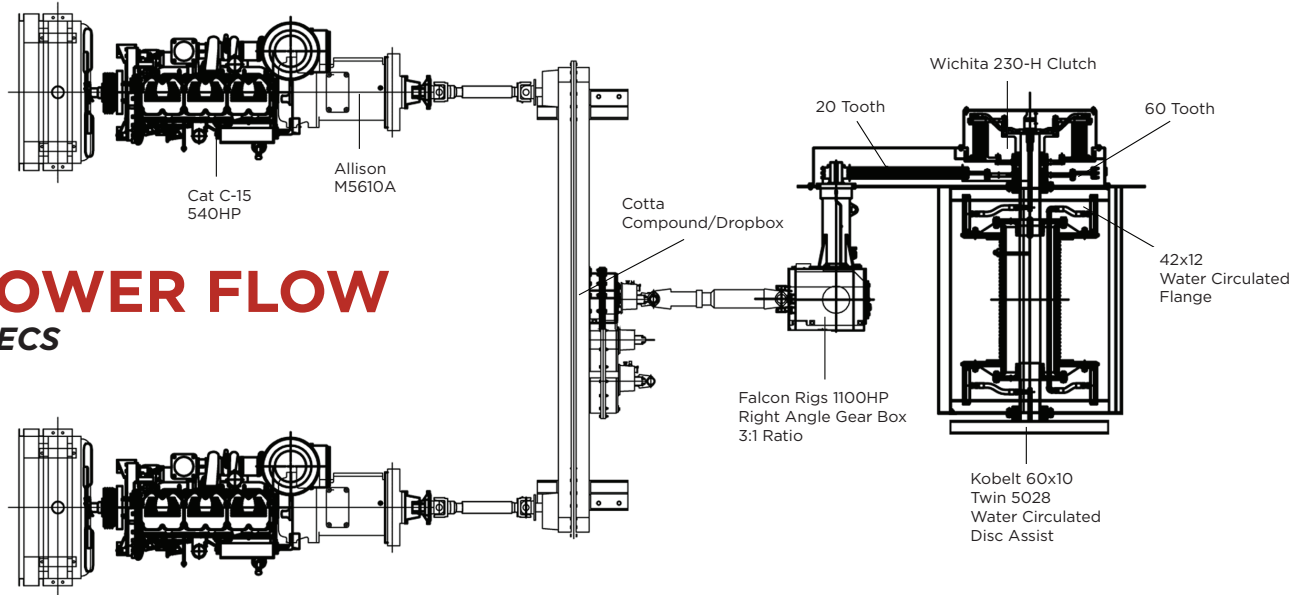

FALCON RIGS



DR-1000



POWER FLOW SPECS

RIG DIAGRAM

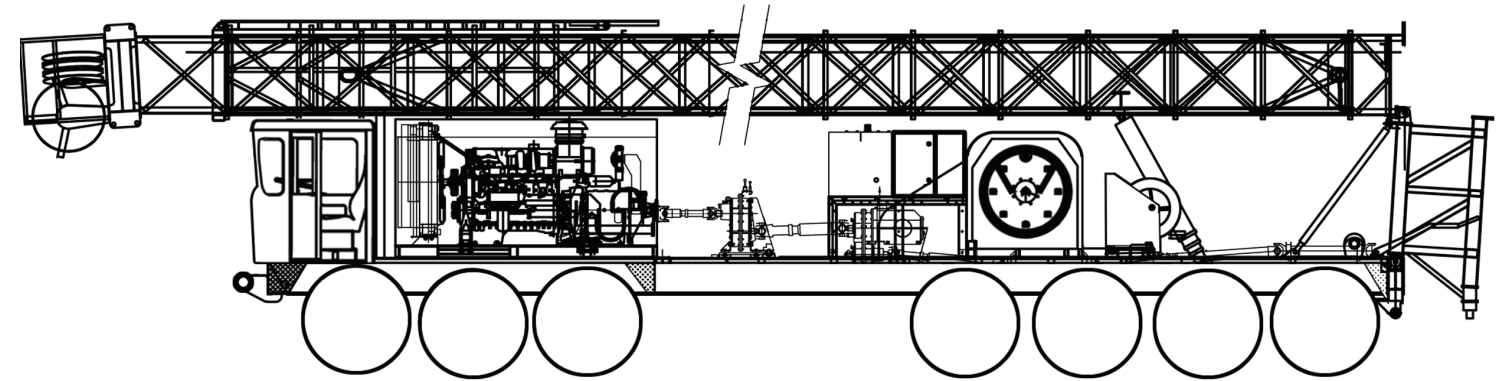

Draw Works Model 1000/42x12

Main Drum

- Hardened overlaid demountable water circulated steel brake rims are 42in diameter x 12in wide. Drum shaft diameter is 8 1/2in 1 1/8in wire line size standard.

Draw Works Features

- Twin Kobelt 5028 on a single 60x10 water circulated disc assist brake
- 1 1/8in Lebus grooving on main drum
- 230-H Wichita Clutch on main drum

Mast Model 120/410

(Double Tubing, Triple Rods)-(per API 4F)

- 4-leg fixed base
- Clear height is 120ft below crown
- Static hook load capacity on 10 lines 410,000lbs
- 42in fast line sheave
- 36in dead line sheave
- 36in sheave cluster
- All sheaves mounted on Timken double row bearings
- Racking platform capacity is 12,000ft of 4 1/2in tubing
- Hydraulic rams for raising and telescoping
- Adjustable work platform

OPTIONS

- Mast lighting
- Standpipes

Drive Train

- Standard Twin Caterpillar C15 540hp (Cummins or Detroit Diesel optional)
- Twin Allison M5610A 6-speed transmissions
- Cotta Compound/Dropbox

Carrier

- Standard 7-axle carrier
- (3) Front axles (rated at 25,000lbs each) have spring suspension
- Rear axles (rated at 60,000lbs combined) have walking beam suspension
- Third and fourth (non-driving) rear axles with air bag lift suspension rated at 20,000lbs
- All axles monitored by a Bendix Anti-Lock Brake System

Controls and Hydraulic System

- Controls for all leveling jacks, mast raising and scoping cylinder, engine, transmission, main drum clutch, winch, and road to winch shifting are located at lower operator's station for easy rigup.
- 50gpm hydraulic pump for all rig hydraulics and tong operation
- Filters provided on suction and return lines
- Standard (2) Braden PD12 Service Winch

Rig Options

- Hydraulic oil cooler for continuous use and hot climate applications
- Cold weather engine package with fuel, oil and coolant heaters
- Ventilated engine/transmission enclosure with removable doors
- Folding walkways on off-operator side
- Rotary drive package